



RFTECHNOLOGIES[®]

Staff Alert Panel

Installation Guide

PN 0510-1008-G



RFTECHNOLOGIES[®]

Staff Alert Panel

Installation Guide

PN: 0510-1008-G
Release Date: 12/30/09

Installers must read this Guide before using the Product

Copyright 2004, 2008 by RF Technologies, Inc.

All Rights Reserved. No Part of this work may be reproduced or copied in any form or by any means without written permission from RF Technologies, Inc.





Conforms to **UL Std. 294**

(3048736)

Important Warnings

It is important for your facility to implement and enforce the following WARNINGS in order to keep all equipment functioning properly.

 **WARNING**
INSTALLATION AND CONFIGURATION—It is the responsibility of the facility to follow the installation instructions carefully and to use the components and supplies specified by RF Technologies, Inc. for all installations.
Failure to use the components and supplies specified by RF Technologies, Inc. may result in equipment and/or system failure.

 **WARNING**
SYSTEM MAINTENANCE AND TESTING—It is the responsibility of the facility to establish and facilitate a regular maintenance schedule for your system. This includes regular inspection, testing, and cleaning. RF Technologies, Inc. recommend monthly maintenance and testing of your system. It is also recommended that your facility keep records of maintenance and test completions.
Failure to provide regular maintenance and testing of these products may result in equipment and/or system failure.

 **WARNING**
SYSTEM INSPECTION—It is the responsibility of the facility to establish and facilitate a regular inspection schedule for your system. RF Technologies, Inc. recommend quarterly inspections of your system for safety and performance by a qualified RF Technologies, Inc. representative.
To arrange for a quarterly inspection by RF Technologies, Inc., call our Technical Support Department at (800)-669-9946 or (262) 790-1771.
Failure to provide regular inspection of these products may result in equipment and/or system failure.

 **WARNING**
USER TRAINING—It is the responsibility of the facility to implement structured training procedures for all employees using the system. Only users who have received adequate training on the use of the system should use the system.
Failure to adequately train employees may cause system failure due to user error. In addition, incorrect use of the equipment may also result in system failure.

 **WARNING**
DISPOSAL—At the end of their service life the products described in this manual, as well as accessories (i.e. lithium batteries, banding material, disposable pads, etc.), must be disposed of in compliance with all applicable federal, state and local guidelines regulating the disposal of products containing potential environmental contaminants. Dispose of the packaging material by observing the applicable waste control regulations.

 **WARNING**
PRODUCT WARRANTIES—Failure to follow the Warnings and Cautions in this guide voids any and all Product Warranties.

This page intentionally left blank.

Contents

Preface	1
Overview	1
Intended Audience	1
Additional Detailed Documentation	2
Contact Information	2
Product Warranty	2
Chapter 1	
Installing the Staff Alert Panel	3
Introduction	3
Mounting the Staff Alert Panel	3
Chapter 2	
Wiring the Staff Alert Panel	5
Wiring Devices to the Staff Alert Panel	5
Wiring Two Interconnecting Staff Alert Panels	8
Chapter 3	
Operating the Staff Alert Panel	9
Introduction	9
Power Switch	9
Tone and Volume Adjustments	9
Active LED	9
Zone LED's	9
Relay Output	10
Unused Zones	10

Chapter 4
Testing and Troubleshooting the Staff Alert Panel 11

 Testing the Staff Alert Panel 11

 Troubleshooting the Staff Alert Panel 11

Chapter 5
Staff Alert Panel Specifications 13

 Specifications 13

Preface

Overview

This guide provides detailed information about a component of the 9450 System. It provides detailed instructions about installing the component as well as specific requirements.

The 9450 System monitors doors, elevators, hallways, and stairwells, to assist staff in monitoring patients in a facility. A small Transmitter is placed on the ankle or the wrist of a patient. If a Transmitter is detected in an Exit Alarm Zone, an alarm sounds at the exit. Depending on which equipment you have installed, the 9450 System can automatically lock doors, deactivate elevators, and activate remote cameras.

In addition, if the 9450 System in your facility includes computers, an alarm also sounds at a Central Server and its network of Clients. The Central Server and Clients also identify which patient sounded the alarm and the exit where the alarm occurred.

The 9450 System Cut Band Feature Option provides further security by alerting staff if a Transmitter band is tampered with or cut. Additionally, if your system contains a Staff Alert Panel, a redundant alarm sounds if certain wires are cut or damaged.



WARNING: The 9450 system is designed and intended to work in conjunction with a facility's overall patient security program, including reasonable operating policies and procedures. The 9450 system, by itself, cannot prevent the mismatch, abduction or elopement of patients.

Intended Audience

The Staff Alert Panel Installation Guide is intended for users who install and configure the 9450 System. It includes detailed information about the 9450 System, the Staff Alert Panel, how to wire the Staff Alert Panel to the 9450 System, and the specifications of a Staff Alert Panel.

Additional Detailed Documentation

Documentation for your system is available in Portable Document Format (PDF) on the System Documentation CD-ROM. The CD-ROM is shipped with the system. Please contact your RF Technologies sales representative for replacement CD-ROMs.

Contact Information

For more information about RF Technologies, Inc. products, go to www.rft.com. For technical support, contact (800) 669-9946 or (262) 790-1771. For questions or comments about documentation, contact the RF Technologies Technical Publications team at techpubs@rft.com.

Product Warranty

Product Warranty information can be found on the System Documentation CD-ROM or with your original system proposal and invoice.

Chapter 1

Installing the Staff Alert Panel

Introduction

The Staff Alert Panel receives alarm signals from Exit Alarm Controllers and Alarming Band Receivers and indicates with a tone and a red LED that an alarm has occurred. In the space next to each red LED, you can write a brief description identifying the zone or device that issued the alarm. If your facility requires the Staff Alert Panel to be visible, it must be located on a wall near the Nurses Station; or it can be located elsewhere such as a security office, or a phone operator room.

This chapter provides detailed instructions about mounting, installing and, wiring the Staff Alert Panel to the 9450 System.

Mounting the Staff Alert Panel

You can flush mount or surface mount the Staff Alert panel. Use the following steps to mount the Staff Alert Panel.

To surface mount the staff alert panel



WARNING: When installing a product, you must follow standard, accepted safety practices, such as wearing safety glasses.

1. Using an Allen wrench, remove the four screws that hold the faceplate to the enclosure.
2. Remove the faceplate and electronics.
3. Holding the empty surface-mount enclosure against the wall, mark out the four mounting holes at the back of the enclosure.
4. Drill holes where you made the marks.



WARNING: Before cutting openings or drilling holes through walls, you must verify that you will not strike any wiring.

5. Line up the holes at the back of the enclosure with the newly drilled holes.

- Using four drywall screws, mount the enclosure to the wall.
If the screws will not hit studs, use drywall anchors (not included).

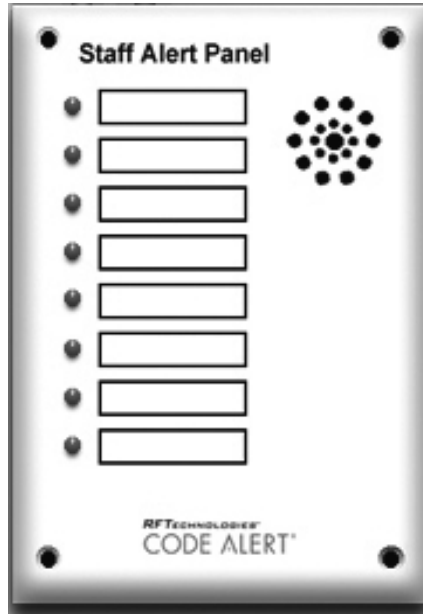

FIGURE 1.1: 9450 Staff Alert Panel

To flush mount the staff alert panel



WARNING: When installing a product, you must follow standard, accepted safety practices, such as wearing safety glasses.

- Using an Allen wrench, remove the four screws that hold the faceplate to the enclosure.
- Remove the faceplate and electronics.
- Holding the empty enclosure against the wall, mark out the area around the enclosure.
- Using a drywall hole saw, cut out the area where the enclosure is to be placed.

Be sure that the area is only as big as the enclosure or the clamps will not attach securely to the wall.



WARNING: Before cutting openings or drilling holes through walls, you must verify that you will not strike any wiring.

- Place the clamps in the enclosure and insert the unit into the wall.
- Tighten the clamps using the provided screws.

Wiring the Staff Alert Panel

Wiring Devices to the Staff Alert Panel

After you mount the Staff Alert Panel, you must connect the Exit Alarm Controllers and Alarming Band Receivers to the Staff Alert Panel. Multiple Exit Alarm Controllers can be connected to represent one Exit Alarm Zone on the Staff Alert Panel. If any one of the Exit Alarm Controllers in the zone issues an alarm, only one LED, representing one zone is illuminated on the Staff Alert Panel.



WARNING: You must verify that the 9450 System's Central Power Supply is OFF before wiring any system components. Failing to do this may result in injury or death.

Use the following steps to wire 9450 devices to the Staff Alert Panel.

To wire Exit Alarm Controllers to the Staff Alert Panel

1. Connect each Exit Alarm Controller in a “series” configuration to the proper Staff Alert Panel using 22-gauge, 4- conductor stranded wire.
2. Connect one of the black wires to the appropriate Zone Terminal on the Staff Alert Panel.
Zone 1 corresponds to the top red LED on the Staff Alert Panel. Zone 8 corresponds to the bottom red LED on the Staff Alert Panel.
3. Connect one of the red wires to the terminal labeled STAFF ALERT C2 on the Exit Alarm Controller, and to the appropriate Common terminal on the Staff Alert Panel.
4. Connect the other red wire to the terminal labeled STAFF ALERT NC2 on the Exit Alarm Controller and to the next device to be wired to the Staff Alert Panel.
5. Splice the black wires together. If the device is the last in the series, connect the black wire from the previous device to the terminal labeled STAFF ALERT NC2.

NOTE: All unused inputs on the Staff Alert panel must be jumpered to common. Any zones not jumpered to common will alarm on power up. The STAFF ALERT connection is a normally closed (N.C.), dry contact. Loss of power to the unit will drop out the relay which will open the contact, causing an alarm condition at the Staff Alert Panel.

- The Staff Alert Panel must receive its power from the Central Power Supply.

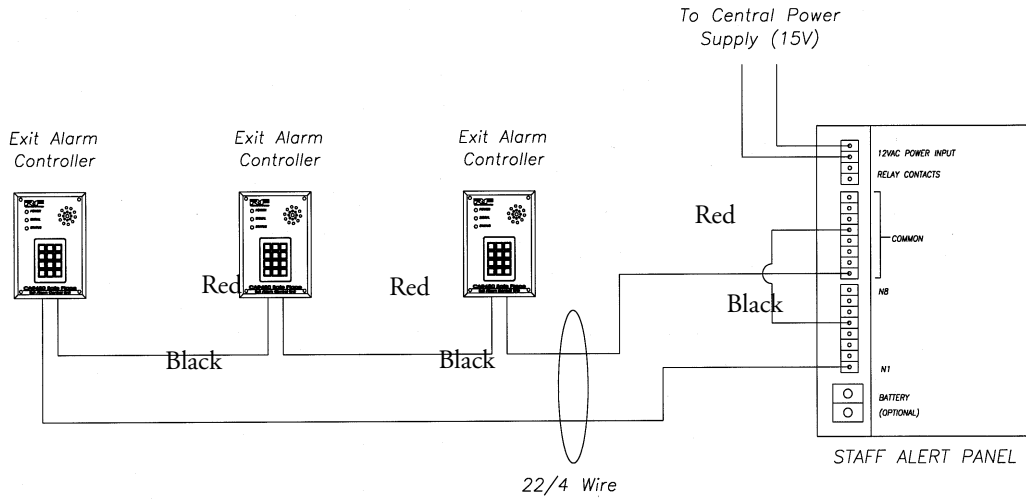

FIGURE 2.1: Wiring the Exit Alarm Controller to the Staff Alert Panel

To wire the Alarming Band Receiver to the Staff Alert Panel

1. Connect the Alarming Band Receiver to the Staff Alert Panel or another device using 22-gauge, 4-conductor stranded wire at the RLY OUT terminal.

The RLY OUT connection is a Normally Closed (NC), dry contact. Loss of power to the unit drops out the relay which opens the contact, causing an alarm condition at the Staff Alert Panel. Multiple receivers can be connected together to represent one zone on the Staff Alert Panel. If any one of the receivers in the zone issues an alarm, only one light or zone is lit on the Staff Alert Panel.

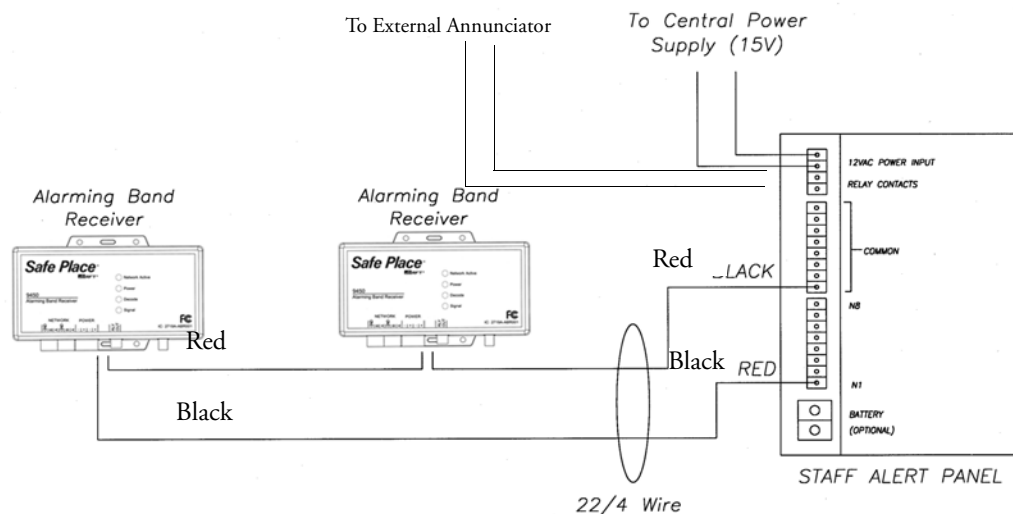

FIGURE 2.2: Wiring the Alarming Band Receiver to the Staff Alert Panel

To wire the Staff Alert Panel to the Central Power Supply

1. Use 16AWG 2-conductor cable to connect the Staff Alert Panel Power terminals to the 9450 System Central Power Supply.

However, if the Staff Alert Panel is remotely located and is inconvenient to wire to the Central Power Supply, a 12-16 V AC Class 2 transformer can be used instead. In this case, locate the transformer in a place where it will not be disturbed.

To wire an external alarm annunciator

The relay output contacts signal when any zone is in alarm. The output contacts are Normally Open or Normally Open dry contacts that close during an alarm.

Wiring Two Interconnecting Staff Alert Panels

It is possible to install two Staff Alert Panels in separate locations, that will receive signals from the same Control Units. The Staff Alert Panels may be connected using 22 AWG, 10-conductor, stranded, jacketed wire. Run the wires according to the diagram below.

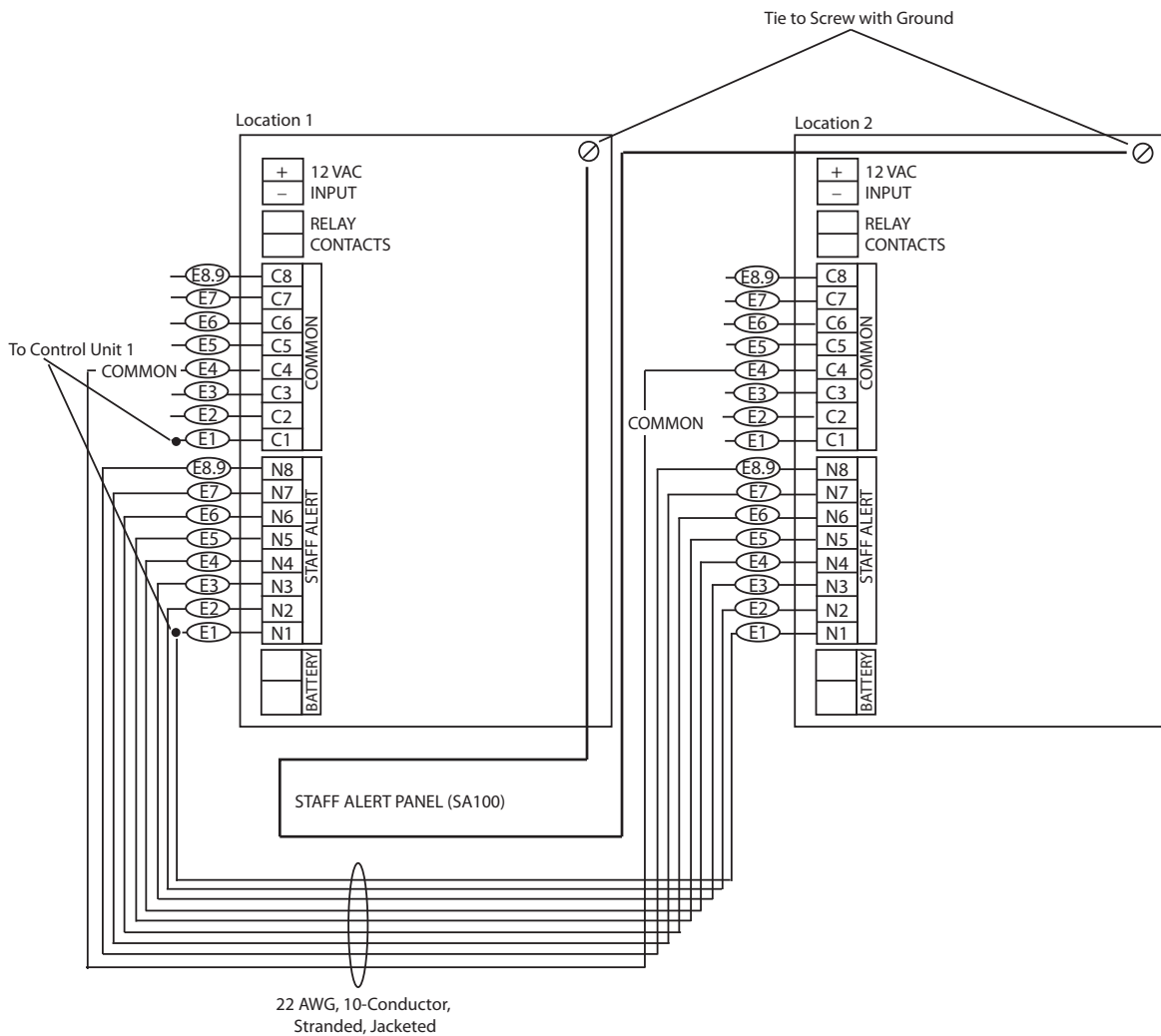

Operating the Staff Alert Panel

Introduction

This chapter provides detailed information on the operation of the Staff Alert Panel.

Power Switch

The Staff Alert Panel must have its Power Switch set to the ON position. The Power Switch is located along the right edge of the circuit board.

Tone and Volume Adjustments

Along the top edge of the circuit board are two adjustment potentiometers for adjusting the volume and tone marked as VOL and TONE. The Volume Pot adjusts the output level of the panel's alarm buzzer. The alarm buzzer sounds whenever any of the alarm zone inputs become active. The Tone adjustment varies the pitch of the alarm buzzer.

Active LED

The front of the Staff Alert Panel includes a green LED marked as ACTIVE. This indicator is continuously illuminated when the Staff Alert Panel is operational. The indicator flashes when any of the alarm zones are active.

Zone LED's

The front of the Staff Alert Panel includes eight red LED's. Each LED represents one alarm zone. A Zone LED is illuminated continuously when an alarm zone is active.

Relay Output

A set of relay contacts, marked as RELAY, is available through a terminal block on the circuit board. The relay output contacts signal when any of the alarm zones are active. The state of the relay output contact switches from Normally Open to Closed during an alarm.

A fully configured 9450 System includes Exit Alarm Controller(s) and Alarm Receivers/Controller(s). Due to the discharge feature within the Server software, alarm indications for these are different. An Exit Alarm Controller always signals its alarm condition on its Staff Alert Panel relay output contacts. However, the Alarming Band Controller or Receiver only signal a cut band alarm on its Staff Alert relay output contacts when it is not in regular communication with the Server.

Unused Zones

On the 9450 Staff Alert Panel all the alarm zones must be wired since the system is supervised, meaning, it expects each zone to have a closed loop circuit. Unused alarm zone connections must be wired from the zone terminal directly to the Common terminal.

Testing and Troubleshooting the Staff Alert Panel

Testing the Staff Alert Panel

Prior to activating the 9450 System, it is important to test the overall functionality of each component and its wiring, including the Staff Alert Panel.



CAUTION: You must test all Staff Alert Panels prior to use to verify proper operation. Failure to test the Staff Alert Panels before use can result in system failure and/or a mismatch, abduction, or elopement. In addition, failure to test Staff Alert Panels voids the RF Technologies Product Warranty.

To test the Staff Alert Panel

1. For each Alarm Zone, go through each Exit Alarm Controller and Alarming Band Receiver individually to ensure proper alarm signalling. To do this:
 - a. Switch the power off momentarily on the device to simulate an alarm condition. The Alarm Condition is signalled by the Staff Alert Panel for each device monitored.

Troubleshooting the Staff Alert Panel

The following section provides detailed information about troubleshooting the Staff Alert Panel. The table provides possible issues and solutions. If you have consistent issues with the system, contact RF Technologies, Inc. Technical Support at 1-800-669-9946.

Issue	Solution
No active light	Verify power.
No Volume during alarm	Verify that the volume control is not all the way down.
Alarm lights when devices are not in alarm	Do the following: <ol style="list-style-type: none">1. Verify unused zones are jumpered out.2. Verify that multiple devices are wired in a closed "series" circuit.
Lock does not trigger when you push on the door	Turn set screw on the side of the trigger block counter-clockwise 1/4 turn at a time.

This page intentionally left blank.

Staff Alert Panel Specifications

Specifications

Size	6.5 x 4.5 x 2.25 inches
Weight	1 lbs
Color	White
Composition	Steel Faceplate and Enclosure
Power	16V AC Class 2 Transformer or 14-18 VAC or DC from the Central Power Supply
Operating Temperature	0-40 degrees Celsius
Display	8 Red Zone LEDs 1 Green Active LED
Relay Output Contacts	1 set, Normally Open
Part Number	9450-0400 (Surface Mount) 9450-1400 (Flush Mount)

This page intentionally left blank.

